

Translated English of Chinese Standard: GB18384-2020

www.ChineseStandard.net → Buy True-PDF → Auto-delivery.

Sales@ChineseStandard.net

GB

NATIONAL STANDARD OF THE
PEOPLE'S REPUBLIC OF CHINA

ICS 43.020

T 40

GB 18384-2020

Replacing GB/T 18384.1-2015, GB/T 18384.2-2015, GB/T 18384.3-2015

Electric vehicles safety requirements

电动汽车安全要求

Issued on: May 12, 2020

Implemented on: January 01, 2021

Issued by: State Administration for Market Regulation;

Standardization Administration of the PRC.

Table of Contents

Foreword	3
Introduction.....	5
1 Scope	6
2 Normative references	6
3 Terms and definitions	7
4 Voltage class	7
5 Safety requirements	8
5.1 Requirements for protection of persons against electric shock.....	8
5.2 Requirements for functional safety protection	14
5.3 Requirements for traction battery	16
5.4 Requirements for collision protection of vehicles	16
5.5 Requirements for flame-retardant protection of vehicles.....	17
5.6 Requirements for vehicle charging interface	17
5.7 Requirements for vehicle alarm and prompt	17
5.8 Requirements for vehicle event data recording.....	17
5.9 Requirements for electromagnetic compatibility.....	17
6 Test methods	17
6.1 Protection against direct contact	17
6.2 Protection against indirect contact	18
6.3 Waterproof of the whole vehicle	25
6.4 Functional safety protection	25
7 Date of implementation	25
Appendix A (Normative) Method for verifying waterproof performance of class B voltage components.....	26
Bibliography.....	28

Foreword

All technical contents of this Standard are mandatory.

This Standard is drafted in accordance with the rules given in GB/T 1.1-2009.

This Standard replaces GB/T 18384.1-2015 "Electrically propelled road vehicles - Safety specifications - Part 1: On-board rechargeable energy storage system (REESS)", GB/T 18384.2-2015 "Electrically propelled road vehicles - Safety specifications - Part 2: Vehicle operational safety means and protection against failures", and GB/T 18384.3-2015 "Electrically propelled road vehicles - Safety specifications - Part 3: Protection of persons against electric shock". Compared with GB/T 18384.1-2015, GB/T 18384.2-2015, and GB/T 18384.3-2015, the main technical changes of this Standard are as follows:

- Modify the high-voltage warning mark of Figure 1 (see 5.1.2.1; see Figure 1 in GB/T 18384.1-2015 and Figure 1 in GB/T 18384.3-2015);
- ADD exemption requirement for top charging device (see 5.1.3.1);
- Modify the requirements for monitoring of insulation resistance from optional requirements to mandatory requirements (see 5.1.4.2; see 8.1 in GB/T 18384.3-2015);
- Modify part of the capacitive coupling requirements (see 5.1.4.4; see 6.3.3 in GB/T 18384.3-2015);
- ADD the equivalent requirements for waterproof requirements of the whole vehicle, that is, the waterproof requirements for components (see 5.1.5);
- ADD requirements for REESS thermal event alarm (see 5.2.2.3);
- Modify the measurement methods for insulation resistance (see 6.2.1 and 6.2.2; see 7.2 in GB/T 18384.3-2015);
- ADD verification test of insulation monitoring function (see 6.2.3);
- ADD the calculation formula for the electric quantity stored in the Y capacitor (see 6.2.5).

This Standard was proposed by and shall be under the jurisdiction of Ministry of Industry and Information Technology of the PRC.

Drafting organizations of this Standard: BYD Auto Industry Co., Ltd., China Automotive Technology and Research Center Co., Ltd., BAIC Beijing Electric Vehicle Co., Ltd., China FAW Group Co., Ltd., SAIC MAXUS Automotive Co.,

Ltd., Shanghai NIO Automobile Co., Ltd., National Automobile Quality Supervision and Test Center (Xiangyang), Chongqing Vehicle Test & Research Institute Co., Ltd., Technical Center of SAIC Motor Corporation Limited, Guangzhou Automobile Group Co., Ltd., Contemporary Amperex Technology Co., Ltd., Zhejiang Geely New Energy Commercial Vehicles Group Co., Ltd., Changchun Automotive Test Center Co., Ltd., Zhejiang Geely Holding Group Co., Ltd., CRRC Electric Vehicle Co., Ltd., CATARC Motor Vehicle Quality Inspection Center (Ningbo) Co., Ltd., Chongqing Changan New Energy Automobile Technology Co., Ltd., Chery New Energy Automotive Technology Co., Ltd., FAW-Volkswagen Automotive Co., Ltd., Pan Asia Technical Automotive Center Co., Ltd., Zhengzhou Yutong Bus Co., Ltd., Anhui Jianghuai Automobile Group Corp., Ltd., Haima New Energy Automobile Co., Ltd., Huawei Technologies Co., Ltd., Chongqing Jinkang New Energy Automobile Co., Ltd., Dongfeng Motor Corporation Technical Center, Shenzhen Denza New Energy Automotive Co., Ltd., Suzhou Inovance Automotive Co., Ltd., SAIC GM Wuling Automobile Co., Ltd.

Main drafters of this Standard: Lian Yubo, Liu Guibin, Tan Yi, Zhang Tianqiang, Lu Chun, Song Fang, Yang Zifa, Yu Yang, Ling Heping, Chen Yanlei, Huang Chendong, Wang Dan, Ye Lei, Wang Hongjun, Lu Kewei, Luo Yuliang, Xu Jinmei, Li Dazhi, Song Guanghui, Cui Fengtao, Luo Xiaodan, Wang Wei, Xiong Le, Yuan Changrong, Zeng Xiangbing, Fang Yunming, Zheng Litao, Ji Bingnan, Tang Xiaohua, Qiao Wancheng, Liu Yongjun, Wu Jieyu, Ma Yueqiang, Zhang Ming, Yang Ruicheng, Zhao Xiaoyu.

The previous editions of the standard replaced by this Standard were released as follows:

- GB/T 18384.1-2001, GB/T 18384.1-2015;
- GB/T 18384.2-2001, GB/T 18384.2-2015;
- GB/T 18384.3-2001, GB/T 18384.3-2015.

Introduction

This Standard specifies the safety requirements and test methods of electric vehicles, to protect the safety of persons in normal use of vehicles. For other safety risks caused by failure behaviors of electronic and electrical safety-related systems, on the basis of meeting the safety requirements of conventional automotive electronic and electrical systems, electric vehicles can refer to other standards (such as GB/T 34590, GB/T 28046) for the safety design and requirements of electronic and electrical systems.

The development of this Standard fully refers to the technical requirements of UN GTR No.20; and, modified in conjunction with the technical level, application scenarios, and testing experience of domestic products.

After the publication of this Standard, it will become an important basic standard for the safety performance test of electric vehicles in China and one of the important technical bases for mandatory inspection of finalization of new electric vehicles and inspection of imported motor vehicles.

Electric vehicles safety requirements

1 Scope

This Standard specifies the safety requirements and test methods for electric vehicles.

This Standard applies to electric vehicles whose maximum working voltage of the on-board drive system is class B voltage.

This Standard does not apply to road vehicles, which are continuously connected to the grid during driving.

2 Normative references

The following documents are indispensable for the application of this document. For the dated references, only the editions with the dates indicated are applicable to this document. For the undated references, the latest edition (including all the amendments) are applicable to this document.

GB/T 4094.2 Electric vehicles - Symbols for controls, indicators and tell-tales

GB 7258-2017 Technical specifications for safety of power-driven vehicles operating on roads

GB 8410 Flammability of automotive interior materials

GB/T 4208-2017 Degrees of protection provided by enclosure (IP code)

GB 11551 The protection of the occupants in the event of a frontal collision for motor vehicle

GB 17354 Front and rear protective devices for passenger cars

GB/T 18387 Limits and test method of magnetic and electric field strength from electric vehicles

GB/T 19596 Terminology of electric vehicles

GB/T 19836 Instrumentation for electric vehicles

GB 20071 The protection of the occupants in the event of a lateral collision

GB/T 20234.1 Connection set for conductive charging of electric vehicles -

Part 1: General requirements

GB 26134 Roof crush resistance of passenger cars

GB/T 31498 The safety requirement of electric vehicle post-crash

GB 34660 Road vehicles - Requirements and test methods of electromagnetic compatibility

GB 38031 Electric vehicles traction battery safety requirements

3 Terms and definitions

The terms and definitions defined in GB/T 19596 and the following ones apply to this document.

3.1

Rechargeable electrical energy storage system; REESS

An energy storage system which is rechargeable and can provide electrical energy.

3.2

Service disconnect

A device used to disconnect high-voltage circuits during check or maintenance of battery packs and fuel cell stacks.

3.3

Conductive connection

USE conductors for conductive connection.

3.4

Direct driving

It refers to that the driver controls the vehicle through the steering wheel, brake pedal, shift mechanism, accelerator pedal, etc.

4 Voltage class

According to the maximum working voltage, the electrical components or

circuits are divided into the following classes, see Table 1.

Table 1 -- Voltage class

In volts

Voltage class	Maximum working voltage <i>U</i>	
	d.c.	a.c. (rms)
A	$0 < U \leq 60$	$0 < U \leq 30$
B	$60 < U \leq 1\ 500$	$30 < U \leq 1\ 000$

For class A voltage circuits and class B voltage circuits which are conductively connected to each other, when one pole of a d.c. live part in the circuit is connected to an electric platform, and the maximum voltage value of any other live part to this pole is not greater than 30 V (a.c.) (rms) and not greater than 60 V (d.c.), then the conductive connection circuit is not completely a class B voltage circuit; only the part, which operates at a class B voltage, is considered a class B voltage circuit.

5 Safety requirements

5.1 Requirements for protection of persons against electric shock

5.1.1 General

Requirements for protection of persons against electric shock shall include the following four parts:

- Requirements for high-voltage marking;
- Requirements for protection against direct contact;
- Requirements for protection against indirect contact;
- Waterproof requirements.

For class A voltage circuits and class B voltage circuits which are conductively connected to each other, when one pole of a d.c. live part in the circuit is connected to an electric platform, and the maximum voltage value of any other live part to this pole is not greater than 30 V (a.c.) (rms) and not greater than 60 V (d.c.), then the requirements of 5.1.4.1, 5.1.4.2, 5.1.4.3, and 5.1.5 do not apply to this circuit (including the d.c. part and a.c. part).

5.1.2 Requirements for high-voltage marking

5.1.2.1 Requirements for high-voltage warning mark

Class B voltage electrical energy storage systems or generating devices, such as REESS and fuel cell stacks, shall be marked with the symbol shown in Figure 1. For class A voltage circuits and class B voltage circuits which are conductively connected to each other, when one pole of a d.c. live part in the circuit is connected to an electric platform, and the maximum voltage value of any other live part to this pole is not greater than 30 V (a.c.) (rms) and not greater than 60 V (d.c.), then REESS does not need to be marked with the symbol shown in Figure 1. Otherwise, regardless of whether class B voltage exists, REESS shall be marked with the symbol shown in Figure 1. The background color of the symbol is yellow; the border and arrow are black.



Figure 1 -- High-voltage warning mark

When the live part of class B voltage can be exposed by removing the barrier or enclosure, the same symbol shall be clearly visible on the barrier and enclosure. When assessing whether this symbol is required, consideration shall be given to the fact that the barrier or enclosure can be entered and removed.

5.1.2.2 Requirements for class B voltage wire marking

The outer skins of cables and wire harnesses in class B voltage circuits shall be distinguished by orange, except those behind the barrier or inside the enclosure which meet the requirements of 5.1.3.2.

5.1.3 Requirements for protection against direct contact

5.1.3.1 General

Protection against direct contact is, through insulating materials, enclosures or barriers, to achieve physical isolation between the human body and class B voltage live parts. The enclosure or the barrier can be either a conductor or an insulator. The requirements for the direct contact protection of specific components shall meet 5.1.3.2~5.1.3.5.

For M₂ and M₃ vehicle types, if a top charging device is arranged on the roof, as shown in Figure 2. If the shortest path length from the lowest step of the vehicle entrance to the exposed class B voltage live part of the top charging device is at least 3 m, the exposed class B voltage live part of the top charging device may not meet the requirements for protection against direct contact.

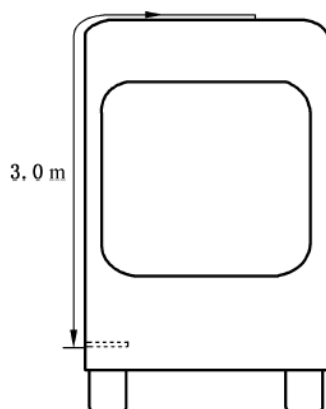

Figure 2 -- Schematic diagram of measurement of shortest path

5.1.3.2 Barrier or enclosure requirements

If protection against electric shock is provided through a barrier or enclosure, class B live parts shall be arranged in the enclosure or behind the barrier, to prevent access to the live part from any direction.

The barrier and the enclosure need to meet the following two requirements:

- a) The barriers and enclosures in the passenger cabin and cargo compartment shall meet the requirements for degree of protection of IPXXD in GB/T 4208-2017. The barriers and enclosures outside the passenger cabin and cargo compartment shall meet the requirements for degree of protection of IPXXB;
- b) Usually, the barrier and the enclosure can only be opened or removed by tools. If the barrier and the enclosure can be opened or removed without using tools, there shall be some way to make the live part of class B voltage therein, within 1 s after the barrier and the enclosure are opened, meet at least one of the following two requirements:
 - The a.c. circuit voltage shall drop to no more than 30 V (a.c.) (rms). The d.c. circuit voltage shall drop to no more than 60 V (d.c.); or
 - The total energy stored in the class B circuit is less than 0.2 J.

5.1.3.3 Connector requirements

The high-voltage connector shall not be opened without tools, except for the following three cases:

- a) After the high-voltage connector is separated, it shall meet the requirements for degree of protection of IPXXB; or

- b) The high-voltage connector requires at least two different actions to separate it from the mutual docking ends. The high-voltage connector has a mechanical locking relationship with some other mechanism. Before the high-voltage connector is opened, the locking mechanism can only be opened by using tools; or
- c) After the high-voltage connector is separated, the voltage of the live part of the connector can, within 1 s, be reduced to not more than 30 V (a.c.) (rms) and not more than 60 V (d.c.).

5.1.3.4 Requirements for high-voltage service disconnect

For vehicles equipped with a high-voltage service disconnect, the high-voltage service disconnect shall not be opened or pulled out without tools, except for the following two cases:

- a) After the high-voltage service disconnect is opened or pulled out, the live part of the class B voltage meets the requirements for degree of protection of IPXXB specified in GB/T 4208-2017; or
- b) Within 1 s after separation, the voltage of the live part of the class B voltage of the high-voltage service disconnect drops to not more than 30 V (a.c.) (rms) and not more than 60 V (d.c.)

5.1.3.5 Requirements for charging socket

When the vehicle charging socket and the vehicle charging plug are disconnected, the vehicle charging socket shall meet at least one of the following requirements:

- a) Within 1 s after disconnection, the voltage of the live part of the class B voltage of the charging socket drops to no more than 30 V (a.c.) (rms) and no more than 60 V (d.c.); or the total energy stored in the circuit is less than 0.2 J; or
- b) When meeting the requirements for degree of protection of IPXXB specified in GB/T 4208-2017 and within 1 min, the voltage of the live part of the class B voltage of the charging socket drops to no more than 30 V (a.c.) (rms) and no more than 60 V (d.c.); or the total energy stored in the circuit is less than 0.2 J.

5.1.4 Requirements for protection against indirect contact

5.1.4.1 Requirements for insulation resistance

Under the maximum working voltage, the insulation resistance of the d.c. circuit

shall not be less than 100 Ω/V ; the a.c. circuit shall not be less than 500 Ω/V . If d.c. and a.c. class B voltage circuits can be connected together conductively, the requirement of insulation resistance not less than 500 Ω/V shall be met. Fuel cell electric vehicles are as shown in Figure 3. If additional protection is added to the a.c. circuit, the combined shall at least meet the requirement of 100 Ω/V .

Additional protection methods shall meet at least one of the following requirements:

- a) There are at least two layers of insulation, barrier, or enclosure; or
- b) Arranged in the enclosure or behind the barrier. These enclosures or barriers shall be able to withstand the pressure of not less than 10 kPa, without obvious plastic deformation.

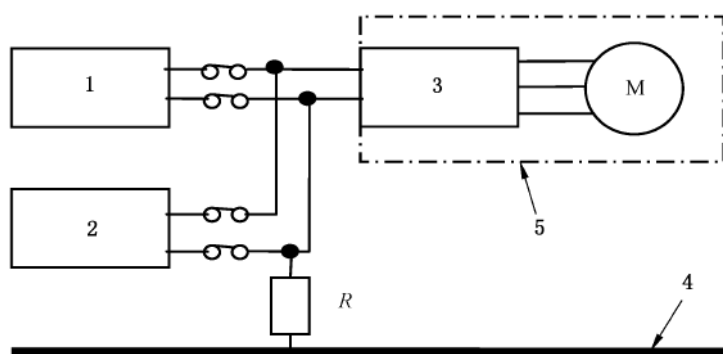

Key:

- 1 - Fuel cell system;
- 2 - Traction battery;
- 3 - Inverter;
- 4 - Electric platform;
- 5 - a.c. circuit.

Figure 3 -- Requirements for the insulation resistance of fuel cell vehicle

5.1.4.2 Requirements for monitoring of insulation resistance

The vehicle shall have the function of insulation resistance monitoring; and can pass the verification test of insulation monitoring function of 6.2.3. When the class B voltage circuit of the vehicle is connected and is not conductively connected to the external power supply, the device can continuously or intermittently detect the insulation resistance value of the vehicle. When the

insulation resistance value is less than the threshold specified by the manufacturer, the driver shall be reminded by an obvious tell-tale (for example: acoustic or optical signal). The threshold specified by the manufacturer shall not be lower than that required by 5.1.4.1.

5.1.4.3 Requirements for potential equalization

Exposed conductive parts for protection against direct contact with class B voltage circuits, such as conductive enclosures and barriers, shall be conductively connected to the electric platform; and, meet the following requirements:

- a) The connection impedance between the exposed conductive part and the electric platform shall not be greater than 0.1Ω ;
- b) In the potential equalization path, any two exposed conductive parts which can be touched by a person at the same time, that is, the resistance between two conductive parts whose distance is not more than 2.5 m shall not be greater than 0.2Ω .

If a soldered connection is used, it is considered to meet the above requirements.

5.1.4.4 Requirements for capacitive coupling

Capacitive coupling shall meet at least one of the following requirements:

- a) In class B voltage circuit, the energy stored in the total capacitance between any class B voltage live part and the electric platform, at its maximum working voltage, shall not be greater than 0.2 J. 0.2 J is the maximum storage energy requirement for the Y capacitor on the positive side or the Y capacitor on the negative side of the class B voltage circuit. In addition, if there are class B voltage circuits isolated from each other, then 0.2 J is a separate requirement for each circuit isolated from each other. Or
- b) Class B voltage circuits have at least two insulation layers, barriers, or enclosures; or are arranged in the enclosure or behind the barrier. These enclosures or barriers shall be able to withstand a pressure of not less than 10 kPa, without obvious plastic deformation.

5.1.4.5 Requirements for charging socket

5.1.4.5.1 Vehicle's a.c. charging socket

The vehicle's a.c. charging socket shall have terminals to connect the electric

platform to the grounding part of the power grid.

The insulation resistance of the vehicle's a.c. charging socket, including the circuit that is conductively connected to the grid during charging, when the charging interface is disconnected, shall not be less than 1 MΩ.

5.1.4.5.2 Vehicle's d.c. charging socket

The vehicle's d.c. charging socket shall have terminals to connect the vehicle electric platform to the protective grounding of the external power supply.

The insulation resistance of the vehicle's d.c. charging socket, including the circuit conductively connected to the vehicle's d.c. charging socket during charging, when the charging interface is disconnected, shall meet the requirements of 5.1.4.1.

5.1.5 Waterproof requirements

For type M₂ and M₃ vehicles, the waterproof requirements of this subclause can be exempted. For other vehicle types, after the simulated cleaning and simulated wading tests, the vehicle shall still meet the insulation resistance requirements in 5.1.4.1.

The manufacturer or vehicle shall meet at least one of the following requirements:

- a) The manufacturer provides the supporting materials required by Appendix A to the testing organization. If the degree of protection of the component is higher than the requirement of Appendix A, it is also deemed to meet the requirements. If the supporting materials provided do not meet the requirements, then the manufacturer shall perform the test according to the requirements of A.2 in Appendix A. Or
- b) According to the test methods of 6.3, carry out simulated cleaning and simulated wading tests on the vehicle. After each test, when the vehicle is still wet, in accordance with the test method in 6.2.1, the insulation resistance shall be measured. The insulation resistance shall meet the requirements of 5.1.4.1. In addition, after the vehicle is placed for 24 h, according to the test method in 6.2.1, the insulation resistance is measured again. The insulation resistance shall meet the requirements of 5.1.4.1.

5.2 Requirements for functional safety protection

5.2.1 Drive system power-on and -off procedures

From the power-off state of the drive system to the "drivable mode", the vehicle shall go through at least two consciously different actions. At least one action is to press the brake pedal.

Only one action is required from the "drivable mode" to the power-off state of the drive system.

The driver shall be continuously or intermittently indicated that the vehicle is already in the "drivable mode". When the driver leaves the vehicle, if the drive system is still in the "drivable mode", the driver shall be alerted by an obvious tell-tale (for example, an acoustic or optical signal).

When the vehicle is stopped, after the drive system is automatically or manually shut down, it can only re-enter the "drivable mode" through the above procedure.

5.2.2 Driving

5.2.2.1 Power reduction prompt

If the electric drive system adopts measures to automatically limit and reduce the driving power of the vehicle, when the limitation and reduction of the driving power affects the driving of the vehicle, the driver shall be alerted by an obvious tell-tale (for example, an acoustic or optical signal).

5.2.2.2 REESS low battery prompt

If the low battery of REESS affects the driving of the vehicle, the driver shall be alerted by an obvious tell-tale (for example, an acoustic or optical signal).

5.2.2.3 REESS thermal event alarm

If REESS is about to have a thermal runaway safety event, the driver shall be alerted by an obvious tell-tale (for example, an acoustic or optical signal).

5.2.2.4 Brake priority

For the vehicle control system, when the brake signal and the acceleration signal occur simultaneously, priority is given to the brake signal.

5.2.3 Gear shift

5.2.3.1 Driving gear shift

When the driver directly drives the vehicle, and switches from the non-driving gear to the driving gear when the vehicle is stationary, the brake pedal shall be depressed.

5.2.3.2 Reverse driving

If the forward and reverse driving directions are changed by changing the rotation direction of the motor, it shall meet one of the following two requirements:

- a) Switching between the forward and reverse driving directions shall be accomplished through two different operational actions by the driver; or
- b) If it is completed by only one operational action of the driver, a safety measure shall be used, so that the mode switch can only be completed when the vehicle is stationary or at a low speed. The judgment of vehicle speed is subject to the display of the instrument in the vehicle.

If the switching between forward and reverse driving directions is not achieved by changing the direction of rotation of the motor, the reverse driving requirements do not apply.

5.2.4 Parking

After the power is cut off, the vehicle shall not be able to produce undesirable driving caused by its own electric drive system.

5.2.5 Locking of conductive connection between vehicle and exterior

When the vehicle is, via a charging cable, connected to a fixed external power source or load, the vehicle shall not be able to move through its own drive system.

5.3 Requirements for traction battery

The safety of traction battery of electric vehicles shall comply with the requirements of GB 38031.

5.4 Requirements for collision protection of vehicles

The frontal collision protection of electric vehicles shall meet the requirements of GB 11551. The lateral collision protection shall meet the requirements of GB 20071. The crash resistance of front and rear protective devices shall meet the requirements of GB 17354. The roof crush resistance shall meet the requirements of GB 26134. The safety of electric vehicle post-crash shall meet the requirements of GB/T 31498.

Note: The scope of application of this subclause is consistent with GB 11551, GB 20071, GB 17354, GB 26134, and GB/T 31498.

5.5 Requirements for flame-retardant protection of vehicles

The flame-retardant properties of interior materials of electric vehicles shall meet the requirements of GB 8410.

Note: The scope of application of this subclause is consistent with GB 8410.

5.6 Requirements for vehicle charging interface

The charging interface of electric vehicles shall meet the requirements of GB/T 20234.1.

Note: The scope of application of this subclause is consistent with GB/T 20234.1.

5.7 Requirements for vehicle alarm and prompt

Electric vehicle alarms and prompts shall comply with the requirements of GB/T 19836 and GB/T 4094.2.

Note: The scope of application of this subclause is consistent with GB/T 19836 and GB/T 4094.2.

5.8 Requirements for vehicle event data recording

Type M₁ electric vehicles shall be equipped with an event data recording system (EDR) or on-board video driving recording device.

5.9 Requirements for electromagnetic compatibility

The electromagnetic compatibility of electric vehicles shall meet the requirements of GB 34660 and GB/T 18387.

Note: The scope of application of this subclause is consistent with GB 34660 and GB/T 18387.

6 Test methods

6.1 Protection against direct contact

During the test of protection against direct contact, the vehicle shall be in a power-off state for the whole vehicle; all barriers and enclosures of the vehicle shall be intact.

During the test process, without using other tools, in accordance with the test methods of IPXXD and IPXXB in GB/T 4208-2017, the testing personnel only use probes or test fingers to perform IP code tests on openings and connectors outside and inside the vehicle.

In addition, through visual inspection and manufacturer's instructions, it is possible to verify the compliance of the connector, high-voltage service disconnect, and vehicle charging socket with the requirements for protection against direct contact.

6.2 Protection against indirect contact

6.2.1 Insulation resistance test of the whole vehicle

6.2.1.1 Test preparation

The internal resistance of the voltage testing tool is not less than 10 M Ω . During the measurement, if the insulation monitoring function will affect the test of the whole vehicle's insulation resistance, the vehicle's insulation monitoring function shall be turned off; or the insulation resistance monitoring unit shall be disconnected from the class B voltage circuit, to avoid affecting the measured value. Otherwise, the manufacturer can choose whether to turn off the insulation monitoring function or disconnect the insulation monitoring unit from the class B voltage circuit.

6.2.1.2 Measurement method for insulation resistance of circuits containing class B voltage power supply

The specific measurement steps are as follows:

- a) POWER on the vehicle, to ensure that all power and electronic switches on the vehicle are activated.
- b) USE the same two voltage testing tools to simultaneously measure the voltage between the two terminals of REESS and the electric platform; as shown in Figure 4. When the reading is stable, the higher one is U_1 ; the lower one is U_1' .
- c) ADD a known resistance R_0 . The resistance value should choose 1 M Ω . As shown in Figure 5, it is connected in parallel between the U_1 side terminal of REESS and the electric platform. Then, use the two voltage testing tools in step b) to simultaneously measure the voltage between the two terminals of REESS and the electric platform. After the reading is stable, the measured values are U_2 and U_2' .

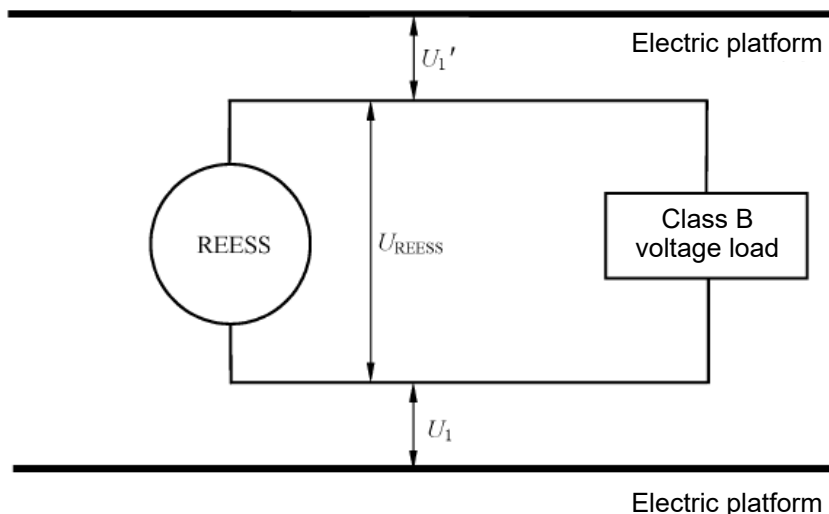

Figure 4 -- Measurement step b) for insulation resistance

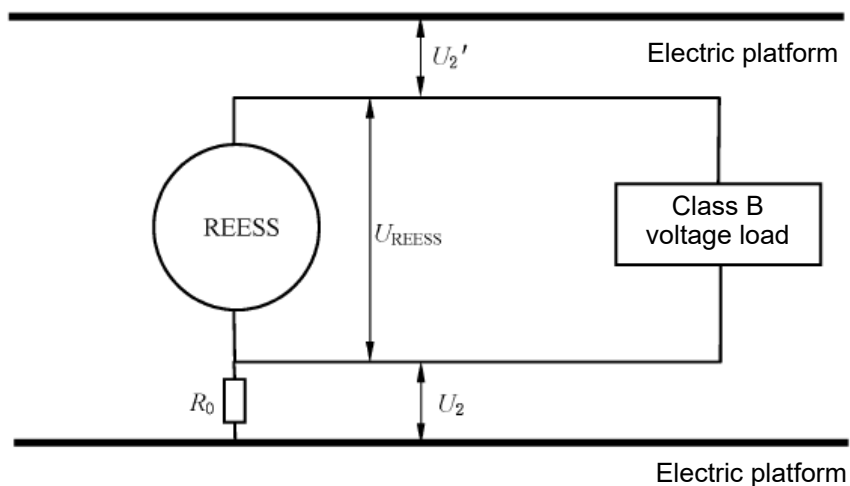

Figure 5 -- Measurement step c) for insulation resistance

d) The insulation resistance R_i is calculated as follows:

R_i can be calculated using R_0 , the four voltage values U_1 , U_1' , U_2 , and U_2' , and the internal resistance r of the voltage testing device substituted into formula (1) or formula (2).

$$\frac{R_i \times r}{R_i + r} = R_0 \left(\frac{U_2'}{U_2} - \frac{U_1'}{U_1} \right) \dots\dots\dots (1)$$

$$R_i = \frac{1}{\frac{1}{R_0 \left(\frac{U_2'}{U_2} - \frac{U_1'}{U_1} \right)} - \frac{1}{r}} \dots\dots\dots (2)$$

6.2.1.3 Measurement method for insulation resistance of class B voltage load without power supply

The specific measurement steps are as follows:

- a) Disconnect all power supplies (including class A voltage power supplies) of the class B voltage load under test;
- b) Conductively connect all class B voltage live parts of the class B voltage load each other;
- c) Conductively connect all exposed conductive parts and class A voltage parts of class B voltage load to the electric platform;
- d) Connect the insulation resistance test equipment between the live part and the electric platform. The equipment can be a megohmmeter;
- e) SET the test voltage of the insulation resistance test equipment to not lower than the highest working voltage of the class B voltage circuit;
- f) READ the insulation resistance value of class B voltage load as R_x .

If there are multiple voltage classes in the conductively-connected circuit in the system (for example: there is a boost converter in the system), and some components cannot withstand the maximum working voltage of the entire circuit, these components can be disconnected. USE their respective maximum working voltages to individually measure the insulation resistance.

6.2.1.4 Calculation of the insulation resistance of the whole vehicle

For the vehicle with all class B voltage loads working at the same time, according to the test method of 6.2.1.2, the insulation resistance of the whole vehicle can be directly measured.

Otherwise, the insulation resistance of the class B voltage load, which cannot be tested in 6.2.1.2, needs to be measured in accordance with 6.2.1.3. The measured result R_i in 6.2.1.2 and the insulation resistance R_x of each class B voltage load measured in 6.2.1.3 are calculated in parallel, which is the insulation resistance of the whole vehicle.

If the whole vehicle has two or more class B voltage circuits isolated from each other, by the method of this subclause, the insulation resistance of each class B voltage circuit can be measured and calculated, respectively. The minimum value is taken as the insulation resistance of the whole vehicle.

6.2.2 Insulation resistance of charging socket

After the test of 6.2.1, continue the insulation resistance test of the charging socket. The test method is as follows:

- a) POWER off the vehicle and ensure that, all power and electronic switches on the vehicle are in the inactive state;
- b) USE an electrical lead to short-circuit the high-voltage terminals of the charging socket, that is, the positive and negative terminals of the d.c. charging socket or the phase terminals of the a.c. charging socket;
- c) Connect the two probes of the insulation resistance test equipment to the high-voltage terminal of the charging socket and the electric platform, respectively. See Figure 6;
- d) The detection voltage of the test equipment shall be set to be greater than the highest charging voltage;
- e) READ the insulation resistance value R_i of the charging port.

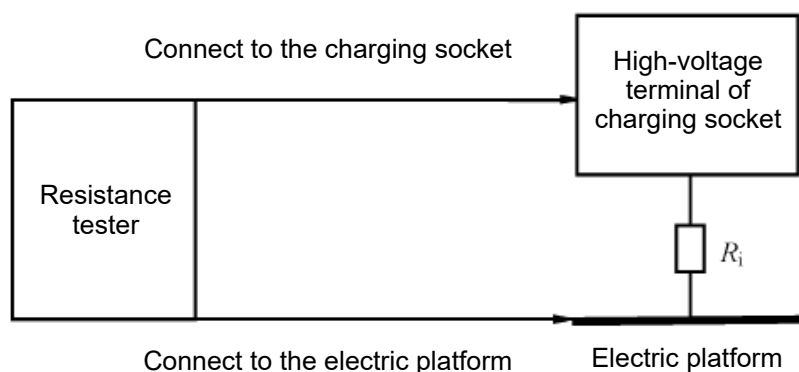

Figure 6 -- Measurement step c) for insulation resistance of charging port

In addition, insulation resistance test equipment can also be used to respectively test the insulation resistance between each high-voltage terminal of the charging socket and the vehicle electric platform. The detection voltage of the test equipment is required to be greater than the highest charging voltage. Then, the parallel result is calculated, which is the insulation resistance of the charging socket.

6.2.3 Verification test of insulation monitoring function

During the test, the vehicle's class B voltage circuit shall be in the on state; and, the insulation monitoring function or equipment has been activated. In the test, adjustable resistors (such as rheostat boxes, etc.) will be used. The maximum resistance of the adjustable resistor is $\geq 10 \text{ M}\Omega$.

The measurement steps are as follows:

- a) At normal temperature, according to the test method of 6.2.1, measure the current insulation resistance value of the whole vehicle as R_i ; and, record the high-voltage side of REESS, where the smaller measured voltage U_1' of the test step b) of 6.2.1.2 is located.
- b) According to the normal operation process of the vehicle under test, make the vehicle enter the "drivable mode".
- c) In step a), if U_1' is at the positive end of REESS, then, as shown in Figure 7, an adjustable resistor is connected in parallel between the positive end of REESS and the vehicle electric platform. Conversely, if U_1' is at the negative end of REESS, an adjustable resistor is connected in parallel between the negative end of REESS and the vehicle electric platform. When starting the measurement, the resistance of the adjustable resistor is set to the maximum value.
- d) According to the requirements of 5.1.4.1, if the minimum insulation resistance is required to be $100 \Omega/V$, then the resistance of the adjustable resistor is reduced to the target value R_x . R_x is calculated according to formula (3):

$$1/[1/(95U_{\text{REESS}}) - 1/R_i] \leq R_x < 1/[1/(100U_{\text{REESS}}) - 1/R_i] \quad \dots\dots\dots(3)$$

According to the requirements of 5.1.4.1, if the minimum insulation resistance is required to be $500 \Omega/V$, then the resistance of the adjustable resistor is reduced to the target value R_x . R_x is calculated according to formula (4):

$$1/[1/(475U_{\text{REESS}}) - 1/R_i] \leq R_x < 1/[1/(500U_{\text{REESS}}) - 1/R_i] \quad \dots\dots\dots(4)$$

Where:

U_{REESS} - The current total voltage of the battery pack, in volts (V).

- e) Observe whether the vehicle has obvious acoustic or optical alarm.

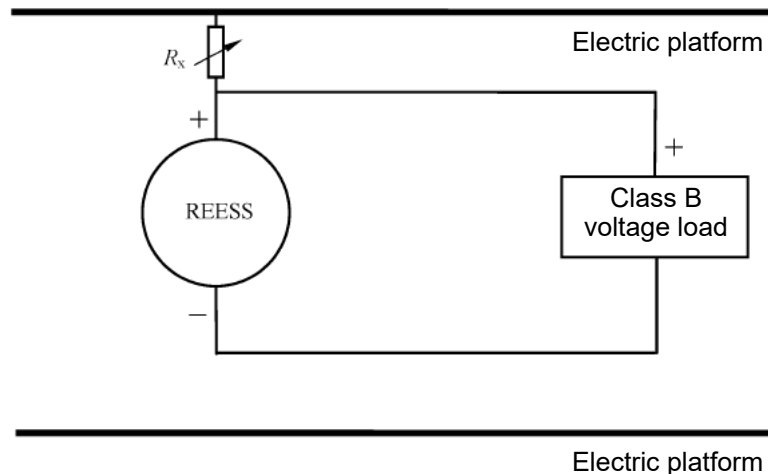

Figure 7 -- Verification test of insulation monitoring

6.2.4 Potential equalization

Potential equalization can be measured directly using a resistance tester; or it can be measured using an independent d.c. power supply in conjunction with current and voltage testing equipment. The measurement current of the resistance tester is adjustable. The resistance test resolution is higher than 0.01 Ω . Independent d.c. power supply voltage can also be adjusted.

The resistance between the two exposed conductive enclosures or barriers can also be calculated from the resistance value of the connection between the exposed conductive enclosure or barrier and the electric platform.

The test method is as follows:

- a) Connect the two probes of the resistance tester to the exposed conductive enclosure or barrier and the electric platform, respectively; as shown in Figure 8;
- b) INCREASE the test current, so that the test current reaches at least 0.2 A;
- c) Connect the two probes of the resistance tester to the two exposed conductive enclosures or barriers, respectively; as shown in Figure 9;
- d) REPEAT step b).

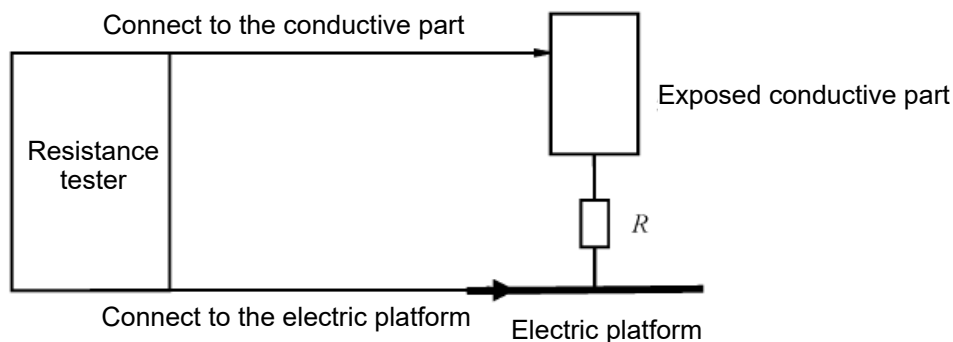

Figure 8 -- Use a resistance tester to test the resistance between the conductive part and the electric platform

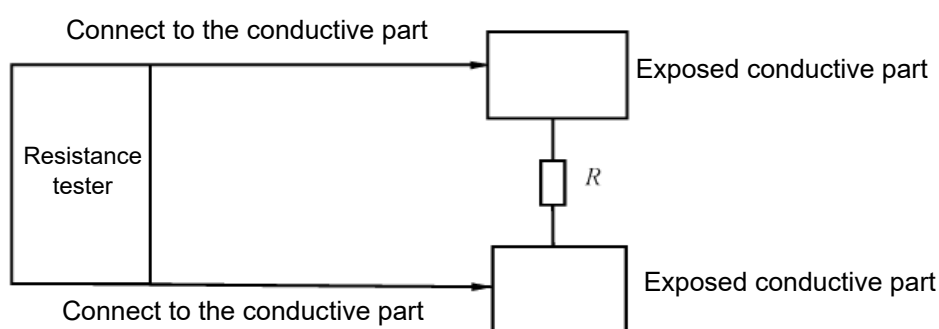

Figure 9 -- Use a resistance tester to test the resistance between two conductive parts

6.2.5 Capacitive coupling

Capacitive coupling test is, through calculation, to obtain the maximum energy stored by Y capacitor in all class B voltage circuits of the whole vehicle. The specific calculation formula is shown in formula (5).

$$Q = \sum_{x=1}^n \frac{C_x \cdot U_x^2}{2} \quad \dots\dots\dots(5)$$

Where:

n - Number of class B voltage units with Y capacitors;

C_x - Y capacitance value of a class B voltage unit, in farads (F);

U_x - The maximum working voltage of the Y capacitor of this class B voltage unit, in volts (V).

6.3 Waterproof of the whole vehicle

6.3.1 Simulated cleaning

The scope of this test is the boundary line of the whole vehicle, such as the seal between two parts, the glass sealing ring, the outer edge of the openable part, the boundary of the front pillar, and the sealing ring of the lamp.

In this test, the IPX5 hose nozzle in GB/T 4208-2017 is used. USE clean water, at a flow rate of $12.5 \text{ L/min} \pm 0.5 \text{ L/min}$, at a speed of $0.10 \text{ m/s} \pm 0.05 \text{ m/s}$; SPRAY water to all boundary lines in all possible directions. The distance from the nozzle to the boundary line is $3.0 \text{ m} \pm 0.5 \text{ m}$.

6.3.2 Simulated wading

In a pool of 100 mm depth, the vehicle shall be driven at a speed of $20 \text{ km/h} \pm 2 \text{ km/h}$ for at least 500 m, for a time of about 1.5 min. If the pool distance is less than 500 m, the test shall be repeated, so that the cumulative wading distance is not less than 500 m. The total test time including the vehicle outside the pool shall be less than 10 min.

6.4 Functional safety protection

According to the functional protection requirements specified in 5.2, the manufacturer shall provide specific program descriptions, including the triggering conditions of protective actions, operation instructions, and alarm prompt signal instructions, etc. According to the description materials, the testing agency will test and verify a real vehicle and compare with the requirements in 5.2, to determine the compliance.

7 Date of implementation

For the vehicle types which newly apply for type approval, this Standard will be implemented from the date of implementation. For vehicle types which have received type approval, this Standard will be implemented from the 13th month from the date of implementation.

Regarding the requirement that type M₁ electric vehicles shall be equipped with an event data recording system or an on-board video driving recording device, the implementation date shall be in accordance with the requirements of 15.4 in GB 7258-2017.

Appendix A

(Normative)

Method for verifying waterproof performance of class B voltage components

A.1 Requirements for information submitted by the manufacturer

A.1.1 The manufacturer shall provide a list of all class B voltage components and their corresponding placement location and installation conditions; see Table A.1.

Table A.1 -- Description list of class B voltage components and their placement location and installation conditions

No.	Name of high-voltage components	The height of the lower surface of the component from the ground	Is there any barrier under the component
	Traction battery		
	Drive motor		
	Steering motor		
	Air-conditioning compressor		
	DC/DC converter		
	Drive motor controller		
	Steering motor controller		
	Air compressor controller		
	High-voltage distribution box		
	High-voltage service switch		
	High-voltage harness and connector		
	Other		

If the test vehicle has class B voltage components listed in Table A.1, the feedback shall be in accordance with Table A.1. If there is no one or several of them, these items are not required. In addition, class B voltage components are not limited to those listed in Table A.1, which shall be provided by the manufacturer according to the specific vehicle.

A.1.2 The manufacturer shall provide a test report on the waterproof grade of each class B voltage component. This report shall be issued by a third-party testing agency. The waterproof grade requirements of each class B voltage component depend on the arrangement height of the vehicle when it is unloaded. The requirements are as follows:

- a) If the height of the lower surface of the component from the ground is less than 300 mm, the high-voltage component shall meet the requirements of IPX7 in GB/T 4208-2017;
- b) If the height of the lower surface of the component from the ground is not less than 300 mm, and there is no barrier under the component, the high-voltage component needs to meet the requirements of IPX5 in GB/T 4208-2017;
- c) If the height of the lower surface of the component from the ground is not less than 300 mm, and there is barrier under the component, the high-voltage component needs to meet the requirements of IPX4 in GB/T 4208-2017.

A.1.3 The manufacturer shall provide the insulation resistance of all class B voltage components in Table A.1 after completing the tests in A.2; and, perform a parallel calculation to obtain the insulation resistance of the whole vehicle, which shall meet the requirements of 5.1.4.1.

A.2 Waterproof test method for class B voltage components

A.2.1 The IPX7, IPX5, and IPX4 tests shall be carried out in accordance with GB/T 4208-2017.

A.2.2 During the testing of IPX7, IPX5, and IPX4, before checking the internal water ingress of class B voltage components, by the test method of 6.2.1, the insulation resistance shall be tested first.

Bibliography

- [1] GB/T 28046 Road vehicles - Environmental conditions and testing for electrical and electronic equipment
- [2] GB/T 34590 Road vehicles - Functional safety
- [3] UN GTR No.20 Electric Vehicle Safety (EVS) (ECE/TRANS/180/Add.20)

END